

Motor contactors CNN series

Application:

Contactors CNN series are using for remote control and protection (in combination with overload relays) of three-phase motors with a nominal power of 4.5 kW to 55 kW (400 V/50 Hz for the use category AC3), and other a.c. and d.c. loads, such as electric ovens, bulbs, electromagnets, capacitors etc.

Advantages:

- In conformity with: IEC 60947-1, IEC 60947-4-1
- High performance and reliability
- Low power loss
- Protection of direct contact from front side - IP20
- Large selection of accessories
- Standard control voltages: 24 VAC, 48 VAC, 110 VAC, 230 VAC, 400 VAC
- Installation on DIN rail and mounting plate
- Small mounting dimensions and overall size
- Up to 4 extended auxiliary contacts (1NO + 1NC or 2NO + 2NC)
- Snap on auxiliaries



Ordering:

CNN	9	1	0	220/230V	50Hz	
	1	2	3	4	5	6

- 1 - Contactor series
- 2 - Rated operational current Ie (AC3,400V/50Hz)
- 3 - Number of NO auxiliary contacts
- 4 - Number of NC auxiliary contacts
- 5 - Control voltage (coil voltage)
- 6 - Frequency of the control voltage

Possibilities

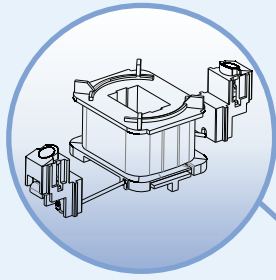

Wide range of coil voltages are provided. The users can change the coil by themselves. AC and DC coils are not compatible with each other. Possible is only the replacement of AC coils with AC and DC coils with DC.

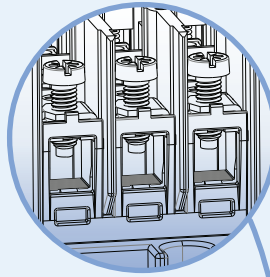

Special clamp terminals are provided for reliable connection of conductors for CNN 50 - CNN 100

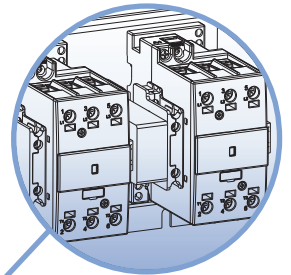

Mechanical interlock is used to prevent the contactors from being energized simultaneously or closing together and causing a short circuit

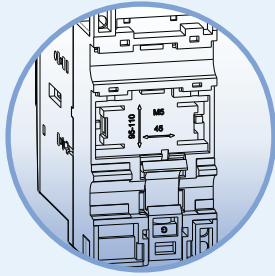

Contactors type CNN can be mounted on DIN rail or directly on the mounting plate. Type CNN 9 to CNN 40 DIN rail 35mm and type CNN 50 to CNN 100 DIN rail 35mm or 75mm

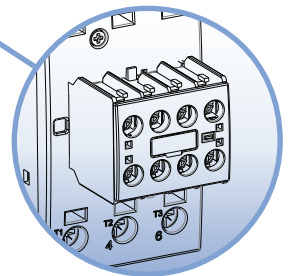
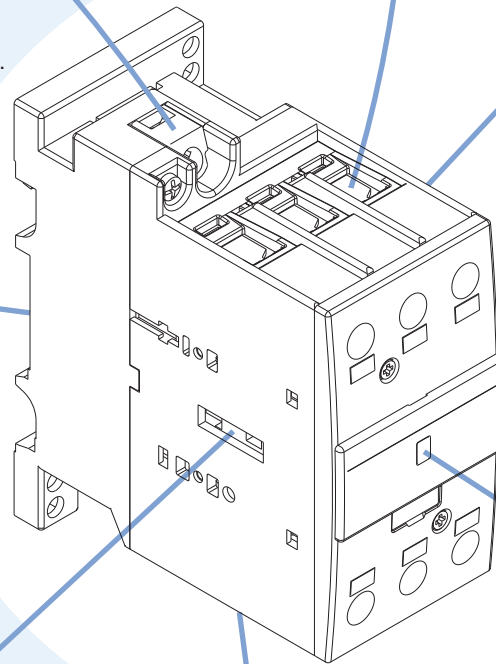

Auxiliary contacts (front mounting)

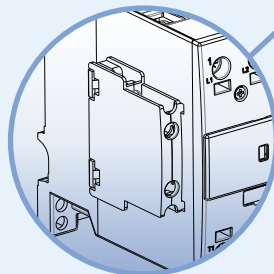

Auxiliary contacts (side mounting)

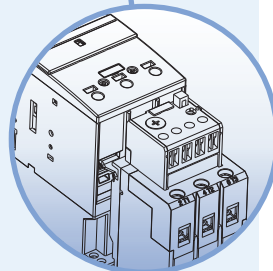

Overload relay (bimetal) can be mounted directly on the contactor or on special carrier adapter.



Motor contactor CNN 9; 9A/4.5kW (AC3,400V/50Hz); 25A (AC1)

Type	Order number	Wiring diagram	Weight [g]	Packing* [pcs]	
CNN 9 10 24V 50Hz	603143		260	24	
CNN 9 10 48V 50Hz	604586		260	24	
CNN 9 10 110V 50Hz	604372		260	24	
CNN 9 10 220/230V 50Hz	604750		260	24	
CNN 9 10 380/400V 50Hz	605022		260	24	
CNN 9 10 24V DC	606473		275	1	
CNN 9 10 220V DC	609001		275	1	
CNN 9 01 24V 50Hz	603144			260	24
CNN 9 01 48V 50Hz	609002			260	24
CNN 9 01 110V 50Hz	603446			260	24
CNN 9 01 220/230V 50Hz	604749	260		24	
CNN 9 01 380/400V 50Hz	605023	260		24	
CNN 9 01 24V DC	607570	275		1	
CNN 9 01 220V DC	609003	275		1	

integrated auxiliary contact (1NO or 1NC)
for DC control voltage with auxiliary contact block BP3 01 DC
*second level packing



Motor contactor CNN 12; 12A/5.7kW (AC3,400V/50Hz); 25A (AC1)

Type	Order number	Wiring diagram	Weight [g]	Packing* [pcs]	
CNN 12 10 24V 50Hz	603145		260	24	
CNN 12 10 48V 50Hz	604585		260	24	
CNN 12 10 110V 50Hz	603002		260	24	
CNN 12 10 220/230V 50Hz	604752		260	24	
CNN 12 10 380/400V 50Hz	606562		260	24	
CNN 12 10 24V DC	605834		275	1	
CNN 12 10 220V DC	609004		275	1	
CNN 12 01 24V 50Hz	603450			260	24
CNN 12 01 48V 50Hz	609005			260	24
CNN 12 01 110V 50Hz	603740			260	24
CNN 12 01 220/230V 50Hz	604751	260		24	
CNN 12 01 380/400V 50Hz	603779	260		24	
CNN 12 01 24V DC	609006	275		1	
CNN 12 01 220V DC	609007	275	1		

integrated auxiliary contact (1NO or 1NC)
for DC control voltage with auxiliary contact block BP3 01 DC
*second level packing

Motor contactor CNN 18; 18A/7.5kW (AC3,400V/50Hz); 30A (AC1)					
Type	Order number	Wiring diagram	Weight [g]	Packing* [pcs]	
CNN 18 10 24V 50Hz	603325		265	24	
CNN 18 10 48V 50Hz	604034		265	24	
CNN 18 10 110V 50Hz	603021		265	24	
CNN 18 10 220/230V 50Hz	604754		265	24	
CNN 18 10 380/400V 50Hz	605024		265	24	
CNN 18 10 24V DC	606440		285	1	
CNN 18 10 220V DC	609008		285	1	
CNN 18 01 24V 50Hz	603287			265	24
CNN 18 01 48V 50Hz	609009			265	24
CNN 18 01 110V 50Hz	609010			265	24
CNN 18 01 220/230V 50Hz	604753	265		24	
CNN 18 01 380/400V 50Hz	605025	265		24	
CNN 18 01 24V DC	609011	285		1	
CNN 18 01 220V DC	609012	285		1	

integrated auxiliary contact (1NO or 1NC)
for DC control voltage with auxiliary contact block BP3 01 DC
*second level packing



Motor contactor CNN 22; 22A/11kW (AC3,400V/50Hz); 30A (AC1)					
Type	Order number	Wiring diagram	Weight [g]	Packing* [pcs]	
CNN 22 10 24V 50Hz	609013		270	24	
CNN 22 10 48V 50Hz	609014		270	24	
CNN 22 10 110V 50Hz	609015		270	24	
CNN 22 10 220/230V 50Hz	606669		270	24	
CNN 22 10 380/400V 50Hz	609016		270	24	
CNN 22 10 24V DC	609017		290	1	
CNN 22 10 220V DC	609018		290	1	
CNN 22 01 24V 50Hz	609019			270	24
CNN 22 01 48V 50Hz	609020			270	24
CNN 22 01 110V 50Hz	609021			270	24
CNN 22 01 220/230V 50Hz	609022	270		24	
CNN 22 01 380/400V 50Hz	609023	270		24	
CNN 22 01 24V DC	609024	290		1	
CNN 22 01 220V DC	609025	290	1		

integrated auxiliary contact (1NO or 1NC)
for DC control voltage with auxiliary contact block BP3 01 DC
*second level packing



Motor contactor CNN 25; 25A/11kW (AC3,400V/50Hz); 40A (AC1)

Type	Order number	Wiring diagram	Weight [g]	Packing* [pcs]
CNN 25 00 24V 50Hz	603425		280	24
CNN 25 00 48V 50Hz	604587		280	24
CNN 25 00 110V 50Hz	603003		280	24
CNN 25 00 220/230V 50Hz	604755		280	24
CNN 25 00 380/400V 50Hz	603395		280	24
CNN 25 10 24V DC	606506		305	1
CNN 25 10 220V DC	609026	305	1	

for DC control voltage with auxiliary contact block BP3 11 DC

*second level packing

Motor contactor CNN 30; 30A/15kW (AC3,400V/50Hz); 40A (AC1)

Type	Order number	Wiring diagram	Weight [g]	Packing* [pcs]
CNN 30 00 24V 50Hz	606008		285	24
CNN 30 00 48V 50Hz	609027		285	24
CNN 30 00 110V 50Hz	606870		285	24
CNN 30 00 220/230V 50Hz	605359		285	24
CNN 30 00 380/400V 50Hz	606009		285	24
CNN 30 10 24V DC	606507		310	1
CNN 30 10 220V DC	607784	310	1	

for DC control voltage with auxiliary contact block BP3 11 DC

*second level packing

Motor contactor CNN 32; 32A/15kW (AC3,400V/50Hz); 50A (AC1)

Type	Order number	Wiring diagram	Weight [g]	Packing* [pcs]
CNN 32 00 24V 50Hz	603451		395	18
CNN 32 00 48V 50Hz	604942		395	18
CNN 32 00 110V 50Hz	603447		395	18
CNN 32 00 220/230V 50Hz	604756		395	18
CNN 32 00 380/400V 50Hz	603396		395	18
CNN 32 10 24V DC	605973		420	1
CNN 32 10 220V DC	609028	420	1	

for DC control voltage with auxiliary contact block BP3 11 DC

 for connecting multi-wire conductor up to 25 mm² must be ordered additional terminal blocks - see page 13

*second level packing

Motor contactor CNN 40; 38A/18.5kW (AC3,400V/50Hz); 50A (AC1)

Type	Order number	Wiring diagram	Weight [g]	Packing* [pcs]
CNN 40 00 24V 50Hz	603452		400	18
CNN 40 00 48V 50Hz	604771		400	18
CNN 40 00 110V 50Hz	603004		400	18
CNN 40 00 220/230V 50Hz	604757		400	18
CNN 40 00 380/400V 50Hz	606010		400	18
CNN 40 10 24V DC	605835		425	1
CNN 40 10 220V DC	606139	425	1	

for DC control voltage with auxiliary contact block BP3 11 DC

 for connecting multi-wire conductor up to 25 mm² must be ordered additional terminal blocks - see page 13

*second level packing

Motor contactor CNN 50; 50A/22kW (AC3,400V/50Hz); 85A (AC1)				
Type	Order number	Wiring diagram	Weight [g]	Packing* [pcs]
CNN 50 00 24V 50Hz	604742		875	10
CNN 50 00 48V 50Hz	605820		875	10
CNN 50 00 110V 50Hz	605557		875	10
CNN 50 00 220/230V 50Hz	604744		875	10
CNN 50 00 380/400V 50Hz	604971		875	10
CNN 50 10 24V DC	605836		895	1
CNN 50 10 220V DC	604948		895	1

for DC control voltage with auxiliary contact block BP5 11 DC
*second level packing



Motor contactor CNN 60; 60A/30kW (AC3,400V/50Hz); 85A (AC1)				
Type	Order number	Wiring diagram	Weight [g]	Packing* [pcs]
CNN 60 00 24V 50Hz	604743		880	10
CNN 60 00 48V 50Hz	605821		880	10
CNN 60 00 110V 50Hz	605169		880	10
CNN 60 00 220/230V 50Hz	604745		880	10
CNN 60 00 380/400V 50Hz	604972		880	10
CNN 60 10 24V DC	607278		900	1
CNN 60 10 220V DC	604947		900	1

for DC control voltage with auxiliary contact block BP5 11 DC
*second level packing

Motor contactor CNN 70; 65A/33kW (AC3,400V/50Hz); 90A (AC1)				
Type	Order number	Wiring diagram	Weight [g]	Packing* [pcs]
CNN 70 00 24V 50Hz	605817		900	10
CNN 70 00 48V 50Hz	605818		900	10
CNN 70 00 110V 50Hz	605819		900	10
CNN 70 00 220/230V 50Hz	605338		900	10
CNN 70 00 380/400V 50Hz	605923		900	10
CNN 70 10 24V DC	606501		920	1
CNN 70 10 220V DC	605895		920	1

for DC control voltage with auxiliary contact block BP5 11 DC
*second level packing



Motor contactor CNN 80; 80A/37kW (AC3,400V/50Hz); 95A (AC1)

Type	Order number	Wiring diagram	Weight [kg]	Packing* [pcs]
CNN 80 00 24V 50Hz	605528		1.3	8
CNN 80 00 48V 50Hz	606095		1.3	8
CNN 80 00 110V 50Hz	605921		1.3	8
CNN 80 00 220/230V 50Hz	605150		1.3	8
CNN 80 00 380/400V 50Hz	605922		1.3	8
CNN 80 10 24V DC	605837		1.33	1
CNN 80 10 220V DC	609029		1.33	1

for DC control voltage with auxiliary contact block BP5 11 DC
*second level packing

Motor contactor CNN 90; 90A/45kW (AC3,400V/50Hz); 105A (AC1)

Type	Order number	Wiring diagram	Weight [kg]	Packing* [pcs]
CNN 90 00 24V 50Hz	605529		1.3	8
CNN 90 00 48V 50Hz	606106		1.3	8
CNN 90 00 110V 50Hz	605883		1.3	8
CNN 90 00 220/230V 50Hz	605203		1.3	8
CNN 90 00 380/400V 50Hz	605646		1.3	8
CNN 90 10 24V DC	605896		1.33	1
CNN 90 10 220V DC	606140		1.33	1

for DC control voltage with auxiliary contact block BP5 11 DC
*second level packing

Motor contactor CNN 100; 100A/55kW (AC3,400V/50Hz); 115A (AC1)

Type	Order number	Wiring diagram	Weight [kg]	Packing* [pcs]
CNN 100 00 24V 50Hz	609030		1.33	8
CNN 100 00 48V 50Hz	609031		1.33	8
CNN 100 00 110V 50Hz	609032		1.33	8
CNN 100 00 230V 50Hz	606454		1.33	8
CNN 100 00 400V 50Hz	609033		1.33	8
CNN 100 10 24V DC	609034		1.36	1
CNN 100 10 220V DC	609035		1.36	1

for DC control voltage with auxiliary contact block BP5 11 DC
*second level packing